



Bekenflo

BEST OEM

INNOVATION

CATALOGUE 2020

BPT series ANSI Chemical Process Pumps

Applications:

Acid Transfer
Brine
Chemical Processing
Petrochemical Processing
Corrosive services
Food and beverage Processing
Hydrocarbon processing
Pharmaceuticals
Polymers
Pulp and paper
Sea water
Slurries
Solvents
Steel and primary metals
Water and waste water Treatment



SPECIFICATIONS:

Speed: 1500rpm--2900rpm/1750rpm--3500rpm
Capacity: 1680m³/h (7400usgpm) (max)
Head: 215m(700ft) (max)
Pressure: 27bar (400psi)
Temperature of liquid: -73°C to 370°C , PH=0-14

Manufactured to meet ANSI/ASME B73.1 standard

Remarks:

We have been OEM for many brands from Europe and USA

Images of the pumps:



Dimensions

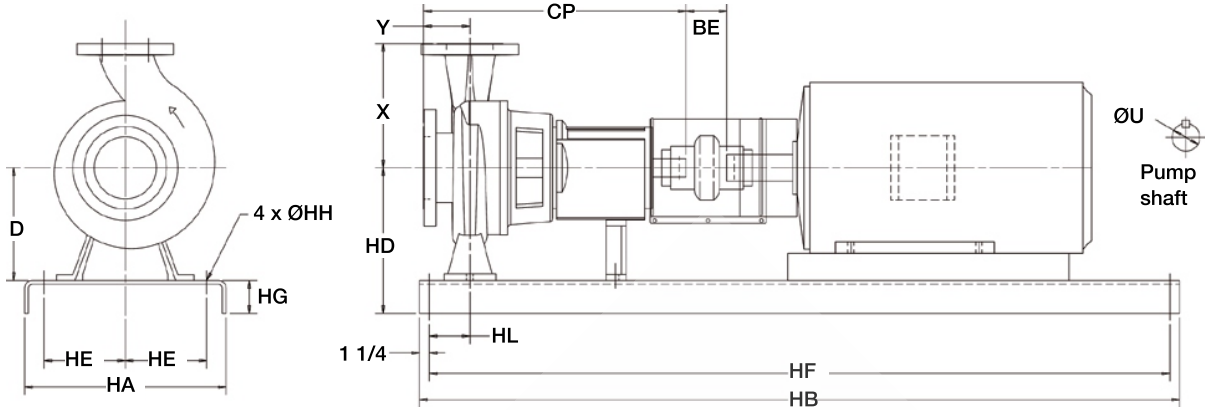

BPT pump dimensions

Group	Pump	Size	CP	Y	X	BE	D	ØU
1	11-1	1.5x1x6	17.5	4	6.5	3.875	5.25	7/8
	11-1B	3x1.5x6	17.5	4	6.5	3.875	5.25	7/8
	11-2	3x2x6	17.5	4	6.5	3.875	5.25	7/8
	11-3**	4x3x6	18	4	8.5	3.875	7	7/8
	12-1	1.5x1x8	17.5	4	6.5	3.875	5.25	7/8
	12-1L	1.5x1x8	17.5	4	6.5	3.875	5.25	7/8
2	21-1B	3x1.5x8.5	23.5	4	8.5	3.875	8.25	1 3/8
	21-2	3x2x8.5	23.5	4	9.5	3.875	8.25	1 3/8
	21-3	4x3x8.5	23.5	4	11	3.875	8.25	1 3/8
	21-4	6x4x8.5	23.5	4	11	3.875	8.25	1 3/8
	22-1	2x1x10	23.5	4	8.5	3.875	8.25	1 3/8
	22-1L	2x1x10	23.5	4	8.5	3.875	8.25	1 3/8
	22-1C	2x1x10C*	23.5	4	8.5	3.875	8.25	1 3/8
	22-1B	3x1.5x10	23.5	4	8.5	3.875	8.25	1 3/8
	22-2	3x2x10	23.5	4	9.5	3.875	8.25	1 3/8
	22-4	6x4x10	23.5	4	13.5	3.875	10	1 3/8
	23-1B	3x1.5x11	23.5	4	10.5	3.875	10	1 3/8
	23-1BL	3x1.5x11	23.5	4	10.5	3.875	10	1 3/8
	23-2	3x2x11	23.5	4	11.5	3.875	10	1 3/8
	23-3	4x3x11	23.5	4	12.5	3.875	10	1 3/8
	24-1B	3x1.5x13	23.5	4	10.5	3.875	10	1 3/8
	24-1BC	3x1.5x13C*	23.5	4	10.5	3.875	10	1 3/8
	24-2	3x2x13	23.5	4	11.5	3.875	10	1 3/8
	24-3	4x3x13	23.5	4	12.5	3.875	10	1 3/8
	24-4	6x4x13	23.5	4	13.5	3.875	10	1 3/8
	3	31-6	8x6x13	33.875	6	16	5.25	14.5
32-6		8x6x15	33.875	6	18	5.25	14.5	2 3/8
32-8C		10x8x15C*	33.875	6	19	5.25	14.5	2 3/8
32-8		10x8x15	33.875	6	19	5.25	14.5	2 3/8
33-4		6x4x17	33.875	6	16	5.25	14.5	2 3/8
33-6		8x6x17	33.875	6	18	5.25	14.5	2 3/8
33-8		10x8x17	33.876	6	19	5.25	14.5	2 3/8

BPT base dimensions (not for construction)

Group	Base	Max Motor Frame	HA	HB	HE	HF	ØHH	HL	HG max	HD max
1	139	184T	15	39	4.5	36.5	3/4	4.5	3.75	9
	148	256T	18	48	6	45.5	3/4	4.5	4.13	10.5
	153	326TS	21	53	7.5	50.5	3/4	4.5	4.75	12.88
	245	184T	15	45	4.5	42.5	3/4	4.5	3.75	12/13.75***
2	252	215T	18	52	6	49.5	3/4	4.5	4.13	12.38/14.13***
	258	286T	21	58	7.5	55.5	1	4.5	4.75	13/14.75***
	264	365T	21	64	7.5	61.5	1	4.5	4.75	13/14.75***
	268	405TS	26	68	9.5	65.5	1	4.5	4.75	14.75
	280	449TS	26	80	9.5	77.5	1	4.5	4.75	15.25
3	368	286T	26	68	9.5	65.5	1	6.5	4.75	18.75
	380	405T	26	80	9.5	77.5	1	6.5	4.75	18.75
	398	449T	26	98	9.5	95.5	1	6.5	4.75	18.75

*Designates higher hydraulic range.

**Note that CPT 11-3 is not part of ANSI specification and may have different dimensions.

***Note that numbers depend on pump size D=8.25"/D=10".

Capacity range 3600 rpm

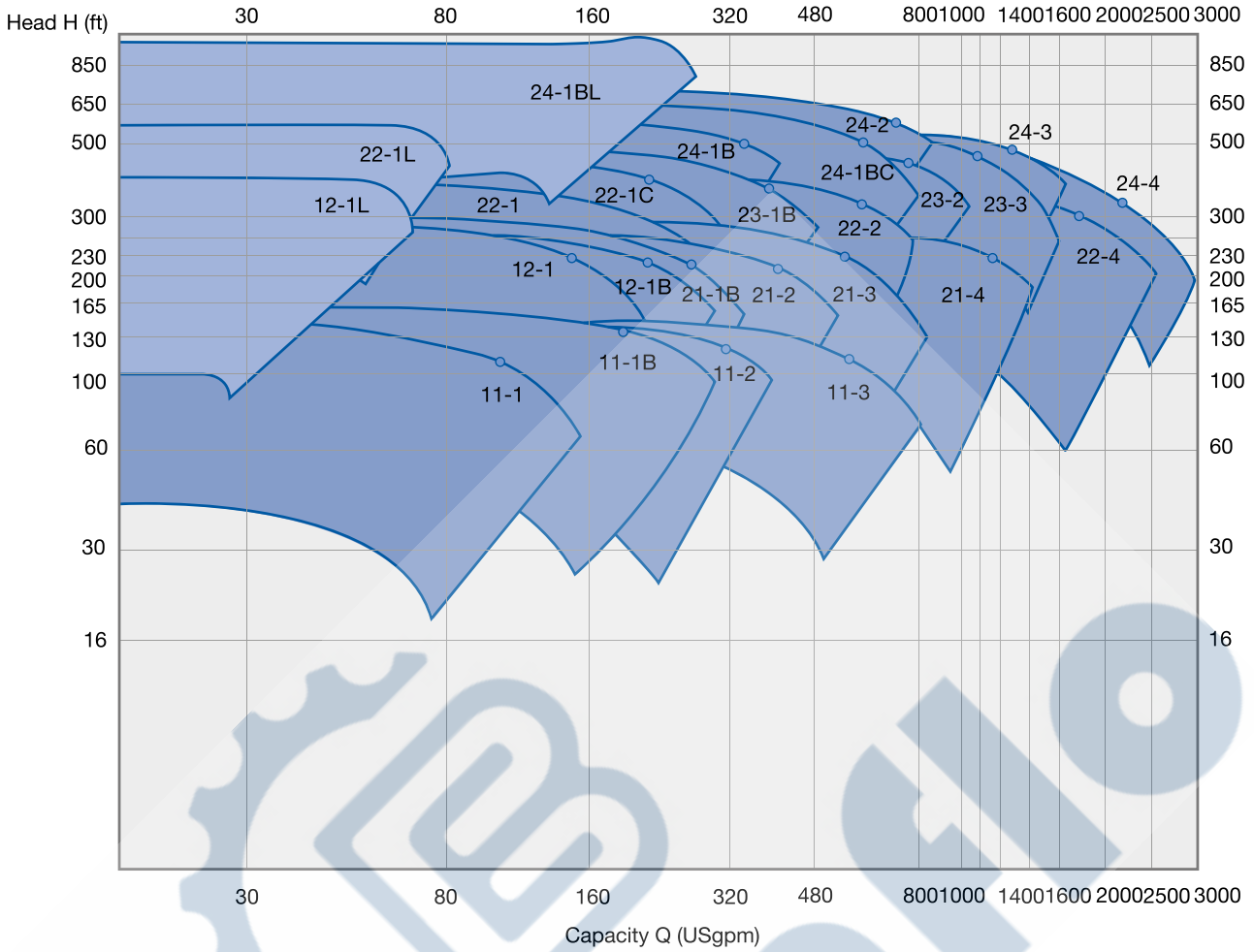

Capacity range 1800 rpm

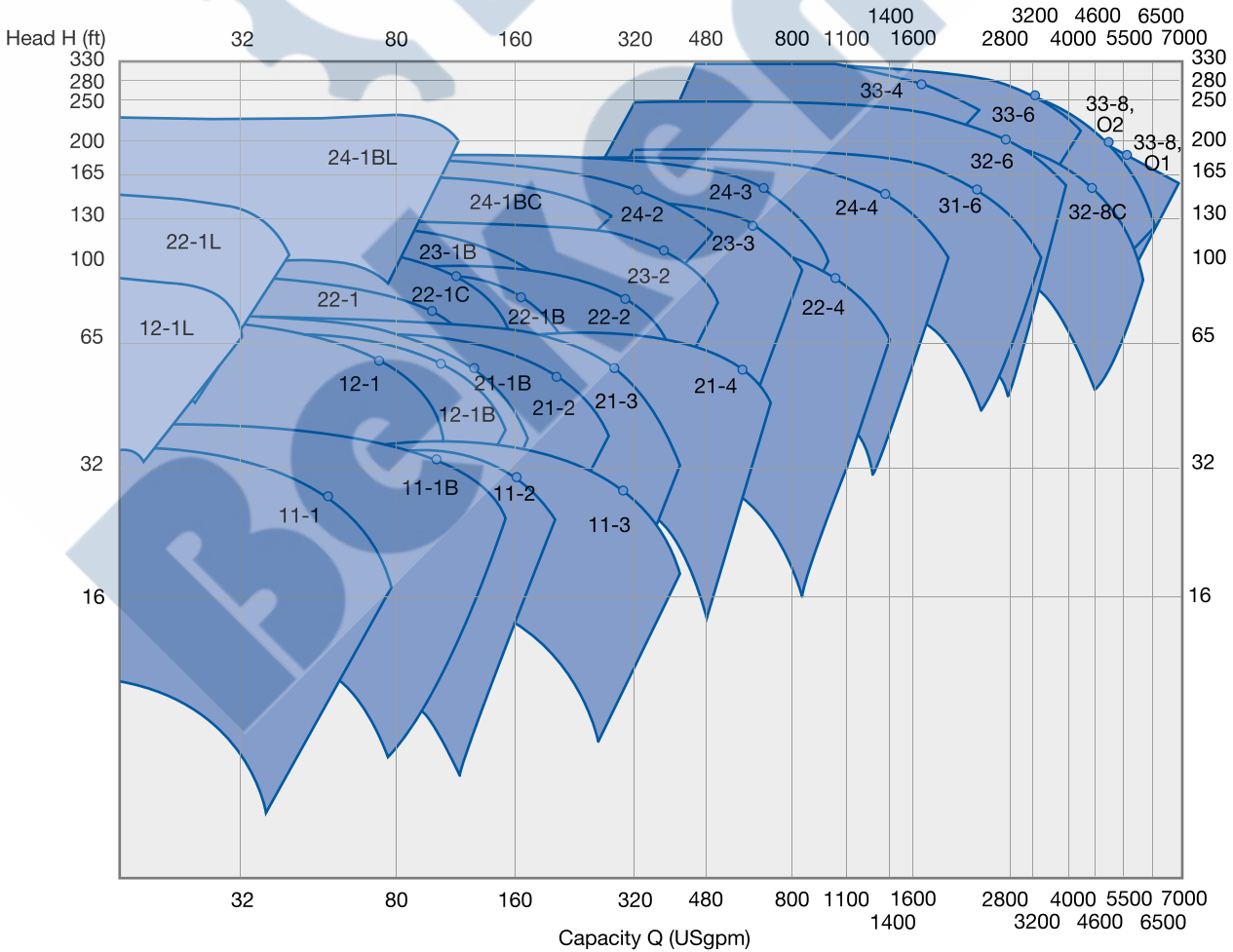

Brands interchangeable:

Sulzer APP/AUP/CPT/MBN/MC/ZE,
Andritz ACP/MC, Godwin, Pioneer, KSB, Goulds 3196,
Durco Mark III, Gorman-rupp. Monoyo/Seepex/Netzsch,
Warman AH, Flowserve LC, Tsurumi pump, etc.



Fuzhou Beken Fluid Co.,LTD.

Add:11th floor, ZhongMing TianAo Building,
No.169 Hudong Road, GuLou District, Fuzhou, Fujian, China.

Tel: 0086-591-87557702

Fax: 0086-591-87557702

Website: www.bekenflo.com

Email: sales@bekenflo.com

Mobile: 0086-18065068870.

