



Bekenflo

BEST OEM

INNOVATION

CATALOGUE 2020

BMN series Horizontal Mixed Flow pumps

Applications:

Irrigation
 Industrial Applications
 Drainage
 Shrimp Ponds
 Flooding



SPECIFICATIONS:

Speed: 970rpm(max)
 Capacity: 150m³/h---14500m³/h
 Head: 4m—70m
 Size: 10" —42"

Working Condition:

Generally it is 1Mpa and Temperature of water ≤105°C

Application Std : Flange std can be BS,DIN,ISO,etc

Remarks:

We have been OEM for many brands from Europe and USA
 BMN series is used widely for the irrigation

Constructure:

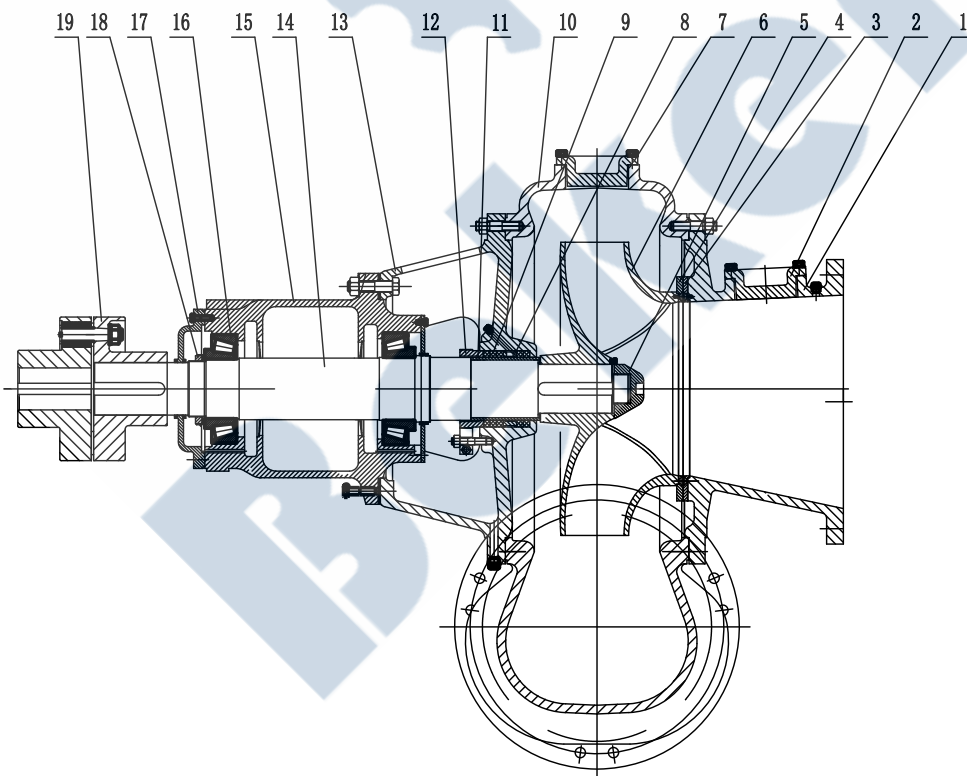

10	Pump casing	2%Ni HT250
9	Packing	Asbestos
8	Seal cage ring	ZCuZn16Si4
7	Hand hole cover	2%Ni HT250
6	Impeller	ZCuZn16Si4
5	Impeller nut	1Cr18Ni9Ti
4	Impeller wear ring	ZG1Cr13
3	Suction head wear ring	ZG3Cr13
2	Hand hole cover	2%Ni HT250
1	Suction head	2%Ni HT250
19	Coupling part	
18	Nut	A2-70
17	Bearing cover	HT250
16	Bearing	SKF
15	Bearing box	HT250
14	Shaft	UNS S-31803
13	Stuffing box head	2%Ni HT250
12	Packing cover	ZCuZn16Si4
11	Shaft sleeve	1Cr18Ni9Ti

Performance Curve:

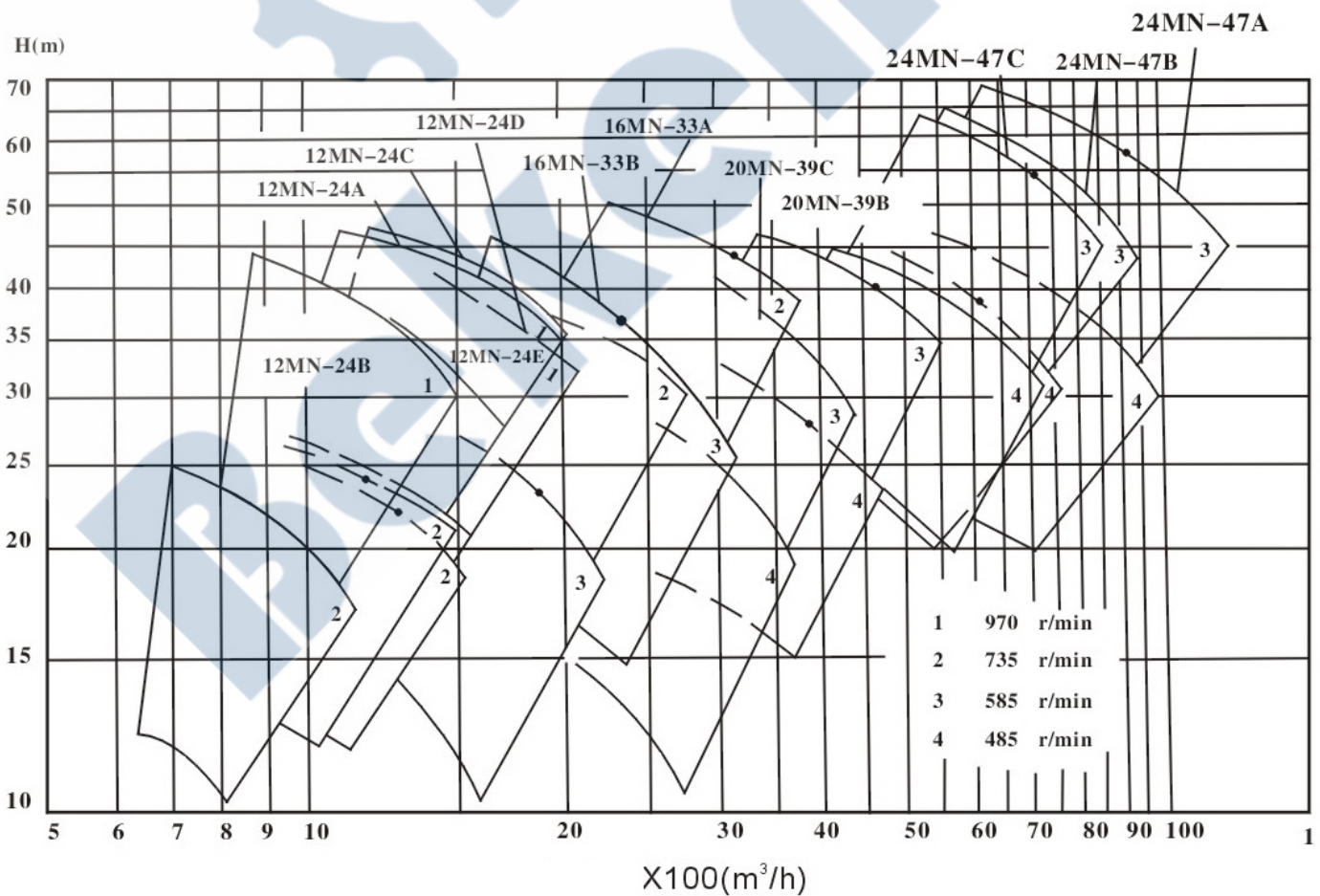
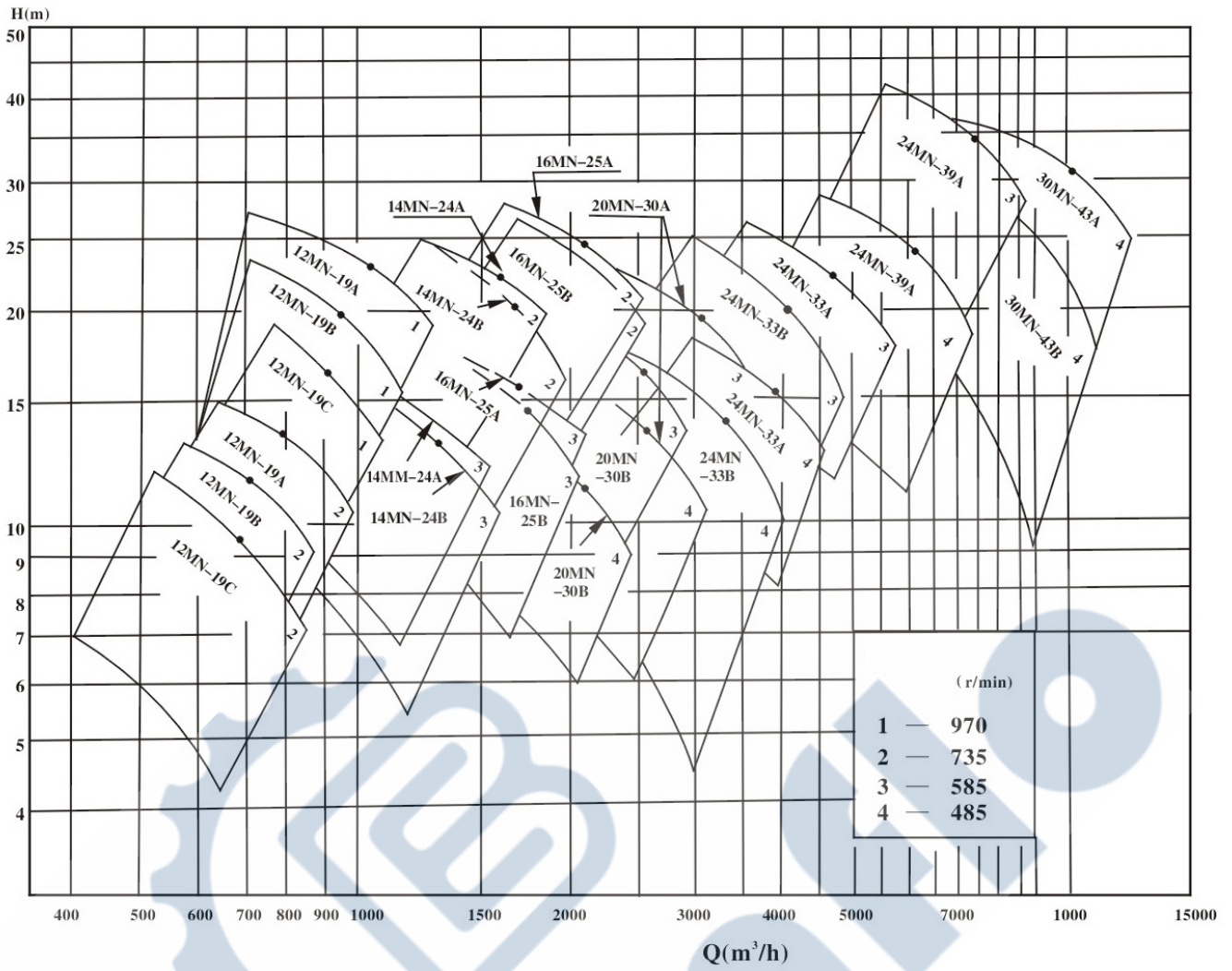

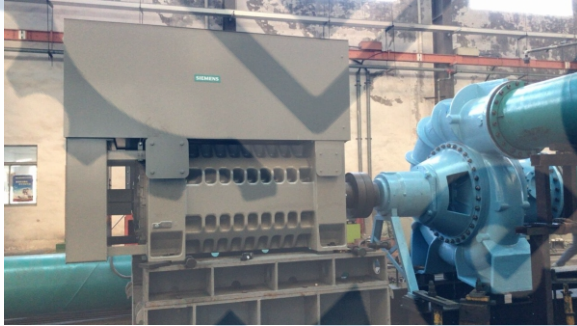
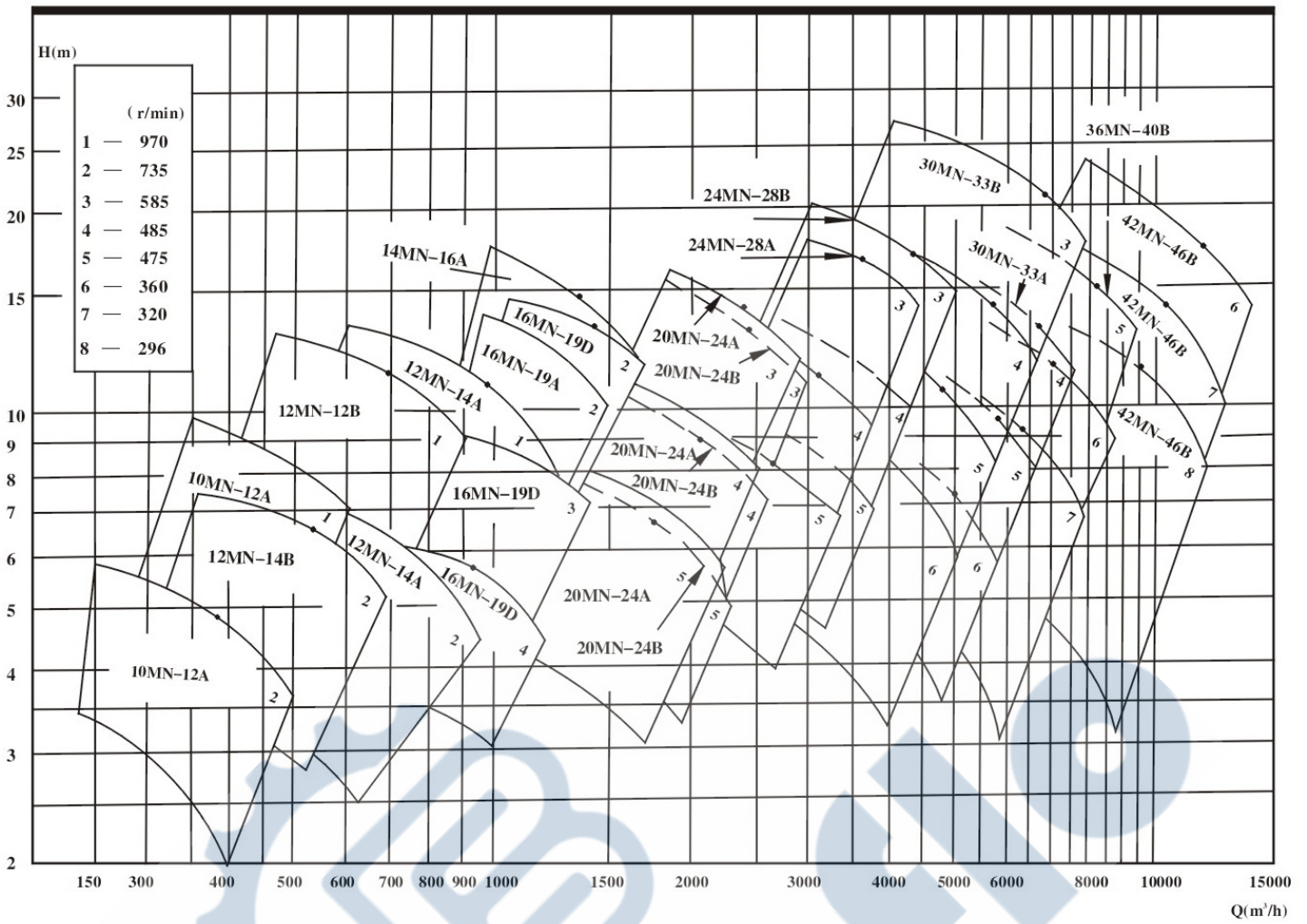

Brands interchangeable:

Sulzer APP/AUP/CPT/MBN/MC/ZE,
Andritz ACP/MC, Godwin, Pioneer, KSB, Goulds 3196,
Durco Mark III, Gorman-rupp. Monoyo/Seepex/Netzsch,
Warman AH, Flowserve LC, Tsurumi pump, etc.



Fuzhou Beken Fluid Co.,LTD.

Add:11th floor, ZhongMing TianAo Building,
No.169 Hudong Road, GuLou District,Fuzhou,Fujian,China.

Tel: 0086-591-87557702

Fax: 0086-591-87557702

Website:www.bekenflo.com

Email: sales@bekenflo.com

Mobile: 0086-18065068870.

